



COMPACT SERIES **DC Electric** SCISSOR LIFTS

The Compact Series DC Electric Scissor Lifts offer Skyjack's easy to service, low maintenance design in a compact and versatile package. Equipped with variable speed front wheel hydraulic drive, and 90° steering, both models in the Compact Series are capable of maneuvering in the smallest spaces.

Featuring a 0,9 m roll out extension deck, these Compact Series models offer work heights up to 7,8 m and up to 30% gradeability.

The SJIII 3215 and SJIII 3219 feature durable steel swing-out component trays, providing unrestricted access for easy maintenance and service.

Consistent with Skyjack's robust and reliable design features, the Compact Series DC Electric Scissor lifts utilize Skyjack's standard colour coded and numbered wiring system with analog based controls.

COMPACT SERIES

DC Electric Scissor Lifts



mainline

PLANT • ACCESS • TRAINING • POWER

Specifications	SJIII 3215	SJIII 3219
A Work Height	6,6 m	7,8 m
B Raised Platform Height	4,6 m	5,8 m
C Lowered Platform Height	0,9 m	1,0 m
D Overall Width	0,8 m	0,8 m
E Overall Length	1,8 m	1,8 m
F Stowed Height (Rails Up)	1,9 m	2,0 m
G Stowed Height (Rails Down)	1,5 m	1,6 m
H Platform Width (Inside Dimension)	0,7 m	0,7 m
I Platform Length (Inside Dimension)	1,6 m	1,6 m
Extension Deck (Roll Out)	0,9 m	0,9 m
Ground Clearance (Stowed)	6,0 cm	6,0 cm
Ground Clearance (raised)	1,8 cm	1,8 cm
Wheelbase	1,4 m	1,4 m
Weight	1120 kg	1312 kg
Gradeability	30%	25%
Turning Radius (Inside)	0"	0"
Turning Radius (Outside)	1,7 m	1,7 m
Lift Time (With Rated Load)	22 sec	21 sec
Drive Speed (Stowed)	3,7 km/h	3,7 km/h
Drive Speed (Raised)	1,1 km/h	1,1 km/h
Maximum Drive Height	Full Height	Full Height
Capacity (Overall)	227 kg	227 kg
Maximum # of Persons	2	2

STANDARD FEATURES

- Drivable at full height
- Variable speed, front two wheel hydraulic drive
- 90° steering (zero inside turning radius)
- Dual holding brakes
- Proportional controls for drive & lift functions
- 0,9 m roll out extension deck
- 24V DC power source
- Low voltage battery protection
- Analog control system
- Colour coded and numbered wiring system
- Up to 30% gradeability
- Solid rubber, non-marking tyres
- Pothole protection system
- Wiring for AC outlet on platform
- Tilt alarm with drive & lift cut-out
- Overload sensing system
- Lowering warning system
- Operator horn
- Half height spring hinged gate
- Lanyard attachment points
- Forklift pockets and tie down/lift lugs

OPTIONS†

- Flashing light
- Shop airline to platform
- Hinged railing system
- Full height spring hinged gate*
- All motion audible alarm
- Pipe racks
- Drywall/board carrier

*not available with hinged railing system

† Capacities, and machine weights may differ when options are added

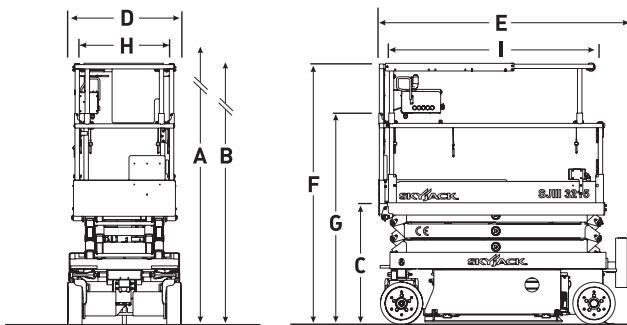

Skyjack UK

Unit 1, Maes-y-Clawdd
Maesbury Road Industrial Estate
Oswestry, Shropshire, SY10 8NN
Tel: +44 1691 676235
Fax: +44 1691 676239
Email: info@skyjackeurope.co.uk

www.skyjack.com

Skyjack AB (Sweden)

Marieholmsgatan 2
415 02 Göteborg
Sweden
Tel: +46 31212245
Fax: +46 31212066

Skyjack SAS (France)

Lieudit Les Pretes
22 bis rue de l'avenir
38150 Chanas France
Tel: +33 474 20 30 20
Fax: +33 474 20 58 93

Skyjack Hebebühnen Gmbh (Germany)

Wullener Feld 27
D-58454 Witten
Tel: +49 2302 2026909
Fax: +49 2302 2025671

This brochure is for illustrative purpose only and based on the latest information at the time of printing. Skyjack Inc. reserves the right to make changes at any time, without notice, to specifications, standard and optional equipment. Consult the Operating Maintenance and Parts Manuals for proper procedures. CE marked work platforms are in conformance to Machinery Directive 2006/42/EC.

SKYJACK™